

**R/A RECEPTACLE MALE  
PRINTED CIRCUIT**

**R197.160.A11**  
Series : SMB CARLOCK

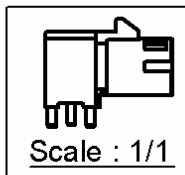

**PANEL CUT OUT**

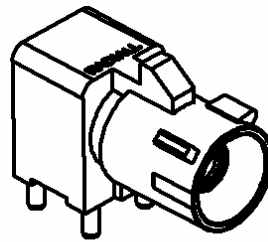
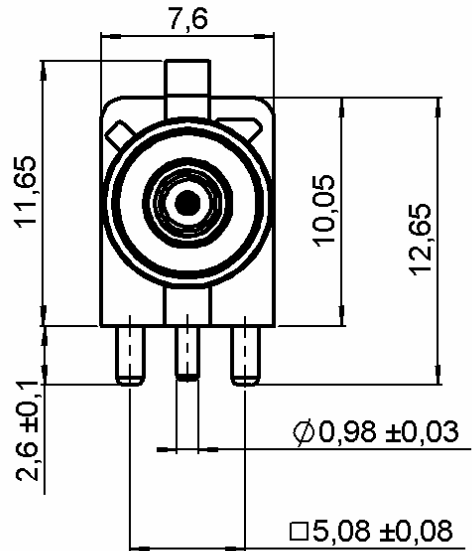
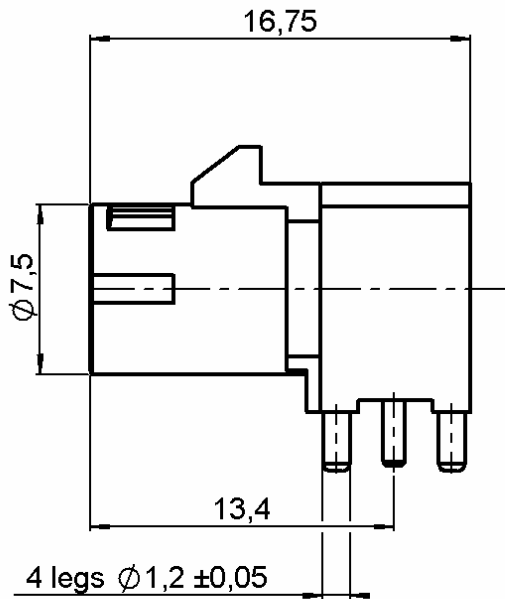
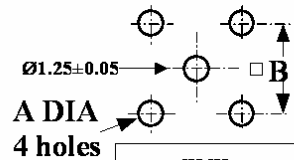

	mm	
	Maxi	mini
A	1.4	1.3
B	5.16	5

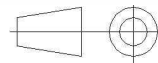

All dimensions are in mm.

COMPONENTS	MATERIALS	PLATING (µm)
BODY	DIE CASTED 5	TIN 3 OVER NICKEL 2 OVER COPPER 8
CENTER CONTACT	BRASS	GOLD 0.5 OVER NICKEL 2
OUTER CONTACT	-	-
INSULATOR	POLYPROPYLENE	-
GASKET	-	-
OTHERS PARTS	BRASS	NICKEL 2
-	-	-
-	-	-

Issue : 0647 A

In the effort to improve our products, we reserve the right to make changes judged to be necessary.



**R/A RECEPTACLE MALE**

**R197.160.A11**

**PRINTED CIRCUIT**

**Series : SMB CARLOCK**

**PACKAGING**

**SPECIFICATION**

Standard	Unit	Other
<b>1600</b>	<b>'W' option</b>	<b>Contact us</b>

**QS9000**

**ELECTRICAL CHARACTERISTICS**

**ENVIRONMENTAL**

Impedance	<b>50</b>	$\Omega$
Frequency	<b>0-4</b>	GHz
VSWR	<b>1.30*</b> + <b>0,0000</b>	x F(GHz) Maxi
Insertion loss	<b>0.25</b>	$\sqrt{F(GHz)}$ dB Maxi
RF leakage	- (	- F(GHz)) dB Maxi
Voltage rating	<b>335</b>	Veff Maxi
Dielectric withstanding voltage	<b>1000</b>	Veff mini
Insulation resistance	<b>1000</b>	M $\Omega$ mini

Operating temperature	<b>-40/+110</b>	$^{\circ}$ C
Hermetic seal	<b>NA</b>	Atm.cm3/s
Panel leakage	<b>NA</b>	

**OTHER CHARACTERISTICS**

Assembly instruction

Others :

\* Coaxial Transmission Line Only

**MECHANICAL CHARACTERISTICS**

Center contact retention		
Axial force – Mating end	<b>10</b>	N mini
Axial force – Opposite end	<b>10</b>	N mini
Torque	<b>NA</b>	N.cm mini
Recommended torque		
Mating	<b>NA</b>	N.cm
Panel nut	<b>NA</b>	N.cm
Mating life	<b>50</b>	Cycles mini
Weight	<b>4,1500</b>	g

Issue : 0647 A

In the effort to improve our products, we reserve the right to make changes judged to be necessary.



**R/A RECEPTACLE MALE****PRINTED CIRCUIT****R197.160.A11**Series : **SMB CARLOCK**

## PACKAGING

### ⇒ TRAY:

Hot formed tray

External dimensions : **350 x 250 x 20 mm**Material : **Antistatic black Polyester (PS)**Number of connector by tray: **320**

### ⇒ CARDBOARD BOX:

Inside dimensions : **365x 265x 90 mm**Number of tray by cardboard box : **5**Number of connector by cardboard box : **1600****Issue : 0647 A**

In the effort to improve our products, we reserve the right to make changes judged to be necessary.

